

duo.
Image Carrier

designed by duo

set.family

The most stylish banner stand

5 good reasons to choose the **set.family**



1. The telescopic pole makes it easy to display your graphic. Simply pull up the pole and tighten it with two locking rings. Both height and width are adjustable allowing you to vary the dimensions of your graphic
2. The Easy Change of Image system (ECI) makes replacing the graphic child's play
3. Hardwearing and stylish design
4. Guaranteed reliability whatever the terrain
5. Rolled up inside its casing , the graphic is protected during transportation.

Choose the **set.** most suited to your needs

set.600 height : 2000 mm, width 600 mm

set.800 height : 2000 mm, width 800 mm

set.1000 height : 2000 mm, width 1000 mm

set.1200 height : 2000 mm, width 1200 mm





set.family applications

The **hello.set** is a case which converts into a counter and holds two banner stands

A high performance exhibition kit

Highly mobile and hardwearing, the ideal travel solution

Quick and easy set up

Discover all the **hello.set** and **hello.xpress** solutions in our brochures



set.family applications

Easy change of formats gives you the creative edge

Wide range of sizes available, 4 possible widths

and adjustable height ranging from 800 mm to 2100 mm to suit your needs



set.family applications

Combining style and signage

Discreet and stylish, the **set.** fits in easily for events such as, conventions, conferences and seminars

The unmatched stability of the foot makes it the ideal display solution for high-traffic events.

The perfect companion for the **set.800**



Combine your **set.800** with a **traveller.1** to add a reception counter and a travel case.



set.family accessory

set.family with spotlight

Why not add lighting to your **set.** ?

The spotlight is fixed to the top of the telescopic pole

3 possible positions

150 Watt power

The spotlight is supplied with a travel cover





Your **set.family** in detail

Extruded aluminium casing

Easy Change of Image (ECI)

Retractable and self locking stabilizing foot

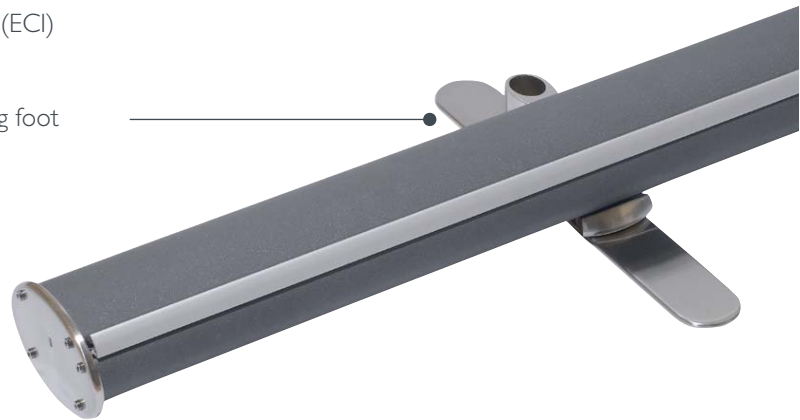

Your **set.family** in detail

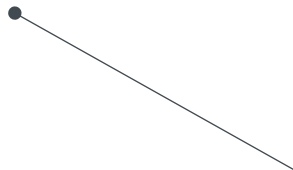

Graphic and spotlight can be attached directly to top of the telescopic pole



Self-locking rings for height adjustment

3 part aluminium telescopic pole.

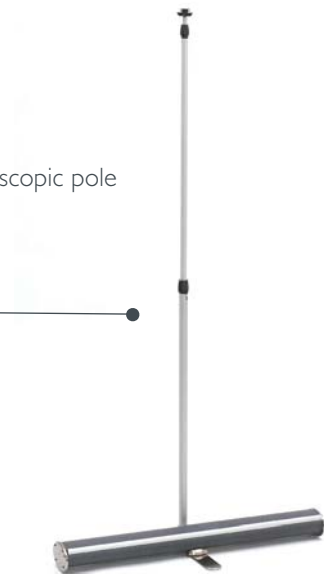



set.family travel solutions

Because your requirements differ depending on whether you travel by plane, by car or on foot, **duo.** offers a full range of carrying cases specially adapted to your needs . Our hardwearing, reinforced, waterproof soft or hard cases offer the ultimate protection for your **set.family** products.



Technical specifications

	set.600	set.800	set.1000	set.1200
Set up	less than a minute	less than a minute	less than a minute	less than a minute
Width	600 mm	800 mm	1000 mm	1200 mm
Weight without graphic	3,4 Kg	3,8 Kg	4,2 Kg	4,6 Kg
Base	Retractable and self locking stabilizing foot			
Tube	170 mm x 900 mm	170 mm x 900 mm	170 mm x 1030 mm	170 mm x 1260 mm
Height	Height of the visual ranging from 2 to 2.20 metres depending on media used			

Set up instructions, videos and printing templates can be downloaded from our website www.duodisplay.com

Guidelines to create your graphic file

Prints are produced from the following four primary colours : Cyan, Magenta, Yellow, Black

Files must be produced in final output size and the text vectorized.

It is advised to include markers and a 1 cm bleed area.

The minimum file resolution is 72 dpi (final output size) and 100 dpi if the file includes text.

We accept file format created with Adobe Photoshop™, Adobe Illustrator™, Adobe InDesign™, Quark Xpress™.

We recommend all fonts be vectorized

By vectorizing all your texts, you avoid font conversion problems.

The following fonts are recommended: Post-Script, OpenType ou TrueType

Please remember to send us your file in one folder including the source image and the Pantone colours.

Also include a proof PDF or JPEG file entitled « control » for verification

Our commitments

Today, commitment to the environment has to be more than just an idea. It must be translated into practical measures ! That is why our Research and Development team strive to design products that are as ergonomic as possible whilst minimizing the quantity of materials used.

By working to reduce the weight of our products, duo. is also reducing the environmental impact of their transportation.

Optimizing the weight and volume of our products not only benefits the customer but also minimizes their environmental footprint throughout their lifecycle (less cardboard, less adhesive tape, less fuel, less storage space...)

Our products are manufactured using recycled aluminium and we work hand in hand with our suppliers to limit waste.

The duo.recycling programme reuses products which have reached the end of their lifecycle.

We now recommend covering our structures with fabrics made from recycled fibers and printed with dye sublimation inks (a printing process using water based inks, containing 80% water).

Today, duo.'s approach is based on a simple idea : offering irresistible eco-friendly products !



duo.

Porteur d'images

France + 33 4 99 63 2050
Canada +1 514 934 0606
U.S.A. +1 312 421 7755

www.duodisplay.com

1751, rue Richardson suite 7.333, Montréal, Qc, H3K 1G8, CANADA